

4

BIM EXECUTION PLAN



MINISTRY OF WORKS



Copyright

Published in 2017 by

ISBN : 978-967-0997-19-3

Construction Industry Development Board (CIDB)
No 45, Tingkat 10,
Menara Dato' Onn,
Putra World Trade Centre (PWTC)
Jalan Tun Ismail
50480, Kuala Lumpur

BIM Guide 4 (Execution)

Copyright © 2017 by CONSTRUCTION INDUSTRY DEVELOPMENT BOARD (CIDB)

All right reserved. No part of the reports may be printed or reproduced or utilised in any form or by any electronic, mechanical, or other means, now known or hereafter invented, including photocopying and recording, or in any information storage or retrieval system, without permission in writing from the publisher.

4

BIM EXECUTION PLAN



MINISTRY OF WORKS



Let's BIM

- ✉: info@mybimcentre.com.my
- 🌐: www.mybimcentre.com.my
- 🐦: [@bimcidb](https://twitter.com/bimcidb)
- 📘: facebook.com/LetsTalkAboutBIM

TABLE OF CONTENT

	A note from CIDB Chief Executive Officer	i
	A note from PWD Director - General	ii
	Acknowledgement	iii
	Preface	iv
1	Introduction to BIM Execution Plan (BEP)	01
2	PWD BIM Execution Process	03
	BIM Project Implementation	03
	PWD BIM Reference Documents	04
	PWD BIM Execution Process	05
3	SIME DARBY Property BIM Execution Process	07
	SDPB BIM Execution Plan	07
	SDPB BIM Reference Documents	08
	SDPB BIM Execution Process	09
	SDPB'S BIM Project Execution Process	10
4	Appendix	11
	Pre-Contract PWD BIM Execution Plan	
	Post-Contract PWD BIM Execution Plan	
	SDPB Project Execution Plan	

A NOTE FROM CIDB CHIEF EXECUTIVE



Dato' Ir. Ahmad 'Asri Abdul Hamid
Chief Executive, CIDB Malaysia

First and foremost, I would like to thank everybody whose hard work and dedication had contributed towards the successful publication of this BIM Guide Book 4.

This book contains specific guidelines for implementation which are required to enhance the direction of BIM adoption at the National level. It also provides direction and framework to initiate BIM process in their respective organisations.

We hope that this BIM Guide will serve as a resource for policymakers, industry players, academicians and researchers towards more effective BIM implementation in Malaysia.

This BIM Guide will be updated periodically based on industry's needs. We look forward to collaborate with more organizations in the public or private sector to further strengthen the BIM implementation in Malaysia.

A NOTE FROM PWD DIRECTOR - GENERAL

The emergence of BIM promises a greater opportunities for construction industry in Malaysia. A decade ago, BIM was just buzzword. Since then, BIM has increasingly been embraced by many local players.

Seeing the benefits, Public Work Department (PWD) has institutionalised the BIM process since 2007. The efforts that have been made are obviously in line with the aims and objectives that we envisioned for Malaysia through the Economic Transformation Programme (ETP), the Eleventh Malaysia Plan (RMK11) and the Construction Industry Transformation Programme (CITP).

Substantial progress has been made by PWD to support the Government initiative for BIM implementation. PWD has set a target that 10% of the Government projects under RMK11 that are above RM 50 million should implement BIM. Until 2017, a total of 18 projects have implemented BIM in PWD. As a government-led initiative, beginning 2018, public projects worth RM100 million and above is required to use the Building Information Modelling (BIM).

The PWD cannot do this initiative alone. We need more stakeholders in the industry to embrace BIM users.

This BIM Guide is timely when BIM has begun to be adopted globally. This movement in return will give a significant impact to transform construction industry landscape in Malaysia. This BIM Guide is bound to be very effective in capturing the attention of policy makers, industry players from the grass root in the construction community.

I am pleased with the effort by CIDB to publish this BIM Guide. I also congratulate all the organisations and individuals that have contributed to bringing this BIM Guide to fruition.



Datuk Seri Dr Roslan Md Taha
Public Works Department (PWD)
Director-General

ACKNOWLEDGEMENT

CIDB has taken effort in the development of BIM Guide. However it could not have been possible without kind support and help from many individual and contributors.

Our sincere thanks to all contributors, industry players and stakeholders for generously supporting the BIM initiatives in Malaysia.

PREFACE

This BIM Execution Plan serves as a guideline and reference for the construction players to implement and execute BIM in their project. This initiative is part of the strategy of Construction Industry Development Board (CIDB) under the Construction Industry Transformation Programme 2016-2020 (CITP) to assist the industry players to move from Level 1 to Level 2 in 2020.

BIM Guide 4: Execution is a continuation from the earlier published BIM Guide books - BIM Guide 1 (Awareness); BIM Guide 2 (Readiness); and BIM Guide 3 (Adoption).

This BIM Guide 4: Execution presents the BIM execution process in an organization and a project. This BIM Guide is divided into three parts:

- Part 1: Introduction to BIM Execution Plan;
- Part 2: A case study on BIM implementation Public Work Department (PWD) and SIME Darby Property Sdn. Bhd.;
- Part 3: Sample of BIM Execution Plan

Every BIM project should develop their own BEP, that is unique based on their project requirements and needs. This BIM Guide serves as industry reference for the common arrangement of BIM execution process. Different readers may have different interests and concerns. Thus, to gain practical knowledge on BIM execution process, it is recommended that readers to attend the BIM training sessions held at myBIM Centre.

This BIM Guide presents two industry examples of the BEP put into practice. Any interested organisations are invited to share and publish case studies on BIM execution process in subsequent versions. Interested parties may contact the BIM Secretariat at myBIM Centre.

On behalf of The Ministry and CIDB, we are proud and grateful for the cooperation of the organisations to share their BIM execution practice and process. We hope more organisations will be interested to share their practices and subsequently become references to other industry players in the future.

Please forward your comments and suggestions to it.pembinaan@cidb.gov.my for further improvement to this BIM Guide.

SECTION 1

INTRODUCTION TO THE BIM EXECUTION PLAN (BEP)

INTRODUCTION TO THE BIM EXECUTION PLAN

BIM Execution Plan (BEP) is a reference document for the contracting parties to execute the BIM project. BEP embodied the process and methodology to deliver the collaborative working practices for BIM project.

The key points for BEP development are:

- The development of BEP should be carried out at the early stage of the project;
- It defines the deliverable strategy for the BIM process to meet the Employer Information Requirement (EIR);
- It should be treated as a reference for BIM contracts. Each requirement must be delineated clearly and agreed by all the parties involved;
- It should be a generic document based on the specific need and requirement of the project;
- It should provide a structured procedure to create, assemble and deliver the information in a BIM model;
- It should specifically assign the responsibilities and liabilities of each party involved;
- It should encourage the use of common standard, procedure and protocol;
- To ensure that the developed design complies with the employer's needs and requirement; and
- To ensure that the employer is able to operate the completed project effectively and efficiently.

There are two types of BEP, namely Pre-Contract and Post-Contract.

Pre-Contract BEP provides methods and procedures to deliver the information for BIM modelling activities during the design stage, while Post-Contract BEP is intended for coordinating and managing the information during the construction and operation stage.

SECTION 2

BIM IMPLEMENTATION IN PUBLIC WORK DEPARTMENT (PWD)

BIM PROJECT IMPLEMENTATION

BIM was introduced in Public Work Department (PWD) in 2007. Since then, various initiatives and strategies formulated to institutionalise BIM in PWD.

PWD inspired to execute BIM project to enhance the productivity and efficiency in delivery government project. Up to year 2017, a total number of 17 projects utilised BIM process.

PWD records and published some BIM reference documents, such as Guidelines, Standards, Work Process Manual, BIM Requirements for Design and Build Projects, and Training Modules.

BIM has been executed in three types of project implementation:

- i. Design and Build;
- ii. Conventional design in-house; and
- iii. Conventional design by consultant.

The aspiration behind BIM implementation in PWD is to enhance the productivity and efficiency in delivering and managing Governments' project.

It is proven that with BIM process execution, productivity can be enhanced through effective collaboration process, increased return of investment, and reliable information to support the decision making process. Efficiency can be enhanced through integrated design process, reliable and accurate cost estimates, reduced financial risk, and reduced potential dispute.

The next section presents the execution of BIM process in the PWD projects.

PWD BIM REFERENCE DOCUMENTS

PWD has taken a transformative effort by publishing BIM reference documents. All information is documented and the be integrated into PWD's Integrated Management System.

These BIM reference documents are applied to all conventional designed BIM projects (in-house) design & build. For BIM projects designed by consultants, these documents serves as a reference for execution, and therefore some modifications must be made to fit the needs and requirements of the project.

For initial stage, the development of these BIM reference documents is based on the Autodesk tools as the main BIM platform. For continual improvement process, these BIM references documents will be reviewed and updated periodically according to the project needs and technological development. This is to optimise the benefits and values of BIM implementation.

Until 2017, PWD published six (6) reference documents for BIM implementation:

- i. PWD BIM Guidelines;
- ii. PWD BIM Standard;
- iii. PWD BIM Work Process Manual;
- iv. PWD BIM Requirements for Design and Build Project;
- v. Term of References for Pre-Approval Plan (PAP); and
- vi. Training Modules.

PWD BIM EXECUTION PROCESS

PWD BEP is part of contractual document which takes precedence in executing BIM project. BEP must be prepared according to the PWD BIM Guidelines Standards and work process.

Each project team should develop and agree with BEP at the beginning stage of the project and BEP must be continually updated.

BEP can assist the project team to:

- i. facilitate information management for the BIM project;
- ii. define the project deliverables as stipulated in the Employer Information Requirement (EIR);
- iii. define the contractual requirement;
- iv. define the roles and responsibilities of parties involved in the BIM project;
- v. define the information exchange requirements;
- vi. provide the key project milestone for the BIM project;
- vii. encourage collaborative working practices;
- viii. identify technology requirements; and
- ix. function as the main reference for BIM execution process.

SECTION 3

SIME DARBY PROPERTY **BIM EXECUTION PLAN**

SDPB BIM EXECUTION PLAN

Building Information Modeling (BIM) was introduced in Sime Darby Property Berhad (SDPB) since 2010. Its goal to support the implementation of Modern Method of Construction (MMC) initiatives.

BIM is executed in major SDPB's project to support design, construction and project management process. To date, a total of 61 percent of 24 phases project for FY17/18 of the SDPB projects implement BIM at various stages.

Level of Development	Percentage/No of project
BIM Usage at LOD 100	67% (16)
BIM Usage at LOD 200	54% (13)
BIM Usage at LOD 300	4% (1)

The SDPB main goals in incorporating BIM are:

- To improve the quality of design solution; and
- To optimise the information exchange process between parties involved in construction project

Various initiatives and strategies are formulated to institutionalise BIM in SDPB. The achievement noted when SDPB successfully published internal BIM references documents such as:

- BIM Guide;
- BIM Project Execution Plan (PEP);
- Standard Design & Specification Guidelines;
- BIM Application Manual; and
- SDPB Revit Template with programable standard plan.

SDPB BIM REFERENCE DOCUMENTS

Initially, SDPB sees BIM as a catalyst to support the implementation of MMC in most of the project. In the process, SDPB realise there is a need to integrate business management strategy (people, process and technology) to improve the delivery and performance of the construction processes.

Hence, the SDPB established in-house BIM Reference Documents as a guideline to standardise the BIM process.

It is expected that:

- The lead consultant (i.e Architect) able to coordinate activities with the other consultants to initiate BIM Project Execution Plan (PEP) at the early stage;
- All parties involve able to distinguish project deliverable based on the BIM requirements;
- All parties involve able to produce a model and drawings according to the BIM Model's requirement.

SDPB's BIM implementation reference documents evolved since 2012, as follows:

Type of Document	Activities	Remarks
BIM Guide	Established in 2012	Implements in all BIM projects
BIM Project Execution Plan (PEP)	Established in 2012	Updated version (2017) : Volume 3 (Combined with BIM Guide)
Standard Design and Specification	Established since 2012	Some modification on design requirement are in constant needs to be updated based on projects and demand.
BIM Application Manual	Established since 2012	No longer applicable due to software update and competency among consultant increased over years
SDPB Revit Template	Established since 2012	No longer applicable due to software API updates.

SDPB BIM EXECUTION PROCESS

SDPB BIM PEP established in 2012 and continuously reviewed based on project needs and requirements. The recent update was done in February 2017 in conjunction to SDPB's BIM Transformation plan and SDPB's BIM roadmap 2017-2011.

SDPB BIM PEP contractual document forming part of Contract Document and Letter of Acceptance. PEP defines the used of BIM uses: for example, design authoring, structural analysis and 3D Coordination. It consists of detailed processes to implement BIM.

Prior project started, consultants are required to agree and provides required information based on PEP term and conditions. The content of the PEP are as follows:

- Contractual Document Review
 - Request for Proposal (RFP) – SDPB BIM requirement embedded with RFP for each project.
 - Term of Reference (TOR) – Consultant BIM team roles & responsibility
 - Letter of Award (LOA) – Deliverables, consultant schedule of payment to include BIM Model LOD stages as part of payment requirement
 - SDP's BIM PEP v3 as legal document for BIM project deliverables
 - SDP's BIM Checklist
- Roles and responsibility of consultant BIM team
 - BIM Manager (lead by architect)
 - BIM Coordinator
 - BIM Modeller
- Intellectual Right
 - BIM Model Release Form (BIM model transfer from Consultant to Contractor)
 - BIM Model continuity from design development stage to construction at LOD 300 for all development – Landed and Integrated

SDPB'S BIM PROJECT EXECUTION PROCESS

To execute project, SDPB will arrange a BIM briefing session with the consultants. SDPB could discourse at great length on client need, BIM standard and requirement, and expected deliverable from BIM process.

Further, the lead consultant (Architect) take action by coordinating BIM process and instigate:

- Design and BIM team roles and responsibilities;
- BIM team information;
- BIM usage and deliverable for project according to BIM Level of Detail (Design and Construction);
- Interoperability of the BIM applications;
- Project Collaboration Plan – The collaboration platform, type of communication and method for project documentation;
- Ownership and copyright of the project (as per Term of Reference);
- Signed and official stamp as legal documents;
- Non-compliance implication;
- BIM Model submission; and
- Checklist for BIM Model audit.

SECTION 4

APPENDIX **PRE-CONTRACT PWD BIM EXECUTION PLAN**

PELAN PELAKSANAAN PROJEK BIM (PRA-KONTRAK)

UNTUK PROJEK REKA DAN BINA

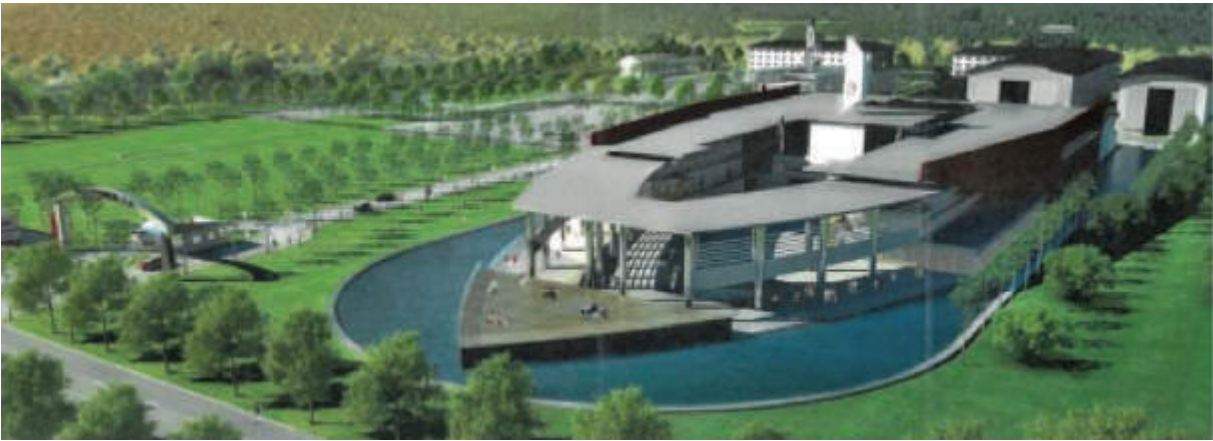

Disediakan : Unit BIM CPAB, Ibu Pejabat Jabatan Kerja Raya Malaysia.

ISI KANDUNGAN

SEKSYEN A: SENARAI AHLI PASUKAN PROJEK	2
SEKSYEN B: OBJEKTIF BIM DAN BIM DELIVERABLES	4
SEKSYEN C: PERANAN DAN TANGGUNGJAWAB	5
SEKSYEN D: PROSES KERJA BIM	6
SEKSYEN E: PENGURUSAN KOORDINASI DAN KOLABORASI	7
SEKSYEN F: STRUKTUR PENAMAAN FAIL	7
SEKSYEN G: KEPERLUAN INFRASTRUKTUR TEKNOLOGI	9
SEKSYEN H: KEPERLUAN PELAKSANAAN BIM DALAM KONTRAK	9

SEKSYEN A : SENARAI AHLI PASUKAN PROJEK

Fungsi	Nama	E-mel	Telefon
Pelanggan			
Head of Project Team (HOPT)			
KPPK			
PPK-BIM Manager			
PP			
Wakil Pegawai Penguasa			
KPPK			
PPK-BIM Coordinator			
PP-BIM Modeler			
Head of Design Team (HODT) - Arkitek			
KPPK			
PPK			
PP			
Head of Design Team (HODT) - Struktur			
KPPK			
PPK-BIM Coordinator			
PP-BIM Modeler			
Head of Design Team (HODT) - Awam			
KPPK			
PPK			
PP			
Head of Design Team (HODT) - Elektrik			
KPPK			
PPK			
PP			
Head of Design Team (HODT) - Mekanikal			
PPK			
PP			
Unit Building Information Modeling (BIM) Cawangan Perancangan Aset Bersepadu			
KPPK			
PPK			
PP			
Unit BIM CPAB (Fasilitator)			
PPK - Penyelia			
PP - Desk Officer			
PP-Arkitek			
PP-Struktur			
PP-Mekanikal			
PP-Elektrik			
PP-Juruukur Bahan			

SEKSYEN B : OBJEKTIF BIM DAN BIM DELIVERABLES

SKOP PEMODELAN

a) Bangunan

b) Infrastruktur (Model Tapak)

FASA	PB	(√/X)	OBJEKTIF	BIM DELIVERABLES
Perancangan (Rekabentuk Konsep LOD100)	JKR	√	Memudahkan kajian keadaan tapak sedia ada	<ul style="list-style-type: none"> ● Model tapak sedia ada ● Laporan analisis tapak
		√	Mengkaji kesesuaian pembangunan di tapak projek	<ul style="list-style-type: none"> ● Massing model
		√	Membantu penyediaan anggaran kos PDA	<ul style="list-style-type: none"> ● Jadual keluasanantai
Rekabentuk Awalan dan Perolehan (LOD200-LOD300)	Petender	√	<ul style="list-style-type: none"> ● Memudahkan kajian rekabentuk ● Mengurus kehendak pelanggan melalui visualisasi 3D 	<ul style="list-style-type: none"> ● Model Rekabentuk Arkitek, Struktur, Mekanikal, Elektrik dan Sivil ● Laporan analisis ruang
		√	Mempercepat dan mengoptimalkan anggaran kerja tanah	<ul style="list-style-type: none"> ● Model rekabentuk Sivil ● Laporan kerja tanah
		√	Membantu penjanaan lukisan	<ul style="list-style-type: none"> ● Lukisan Tender
Rekabentuk Terperinci (LOD300)	Kontraktor	√	<ul style="list-style-type: none"> ● Memudahkan kajian rekabentuk ● Mengurus kehendak pelanggan melalui visualisasi 3D 	<ul style="list-style-type: none"> ● Model koordinasi Arkitek, Struktur, Mekanikal, Elektrik dan Sivil
		√	Mengurangkan percanggahan rekabentuk	<ul style="list-style-type: none"> ● Laporan koordinasi rekabentuk dan Clash Analysis
Pembinaan (LOD400)	Kontraktor	√	Memudahkan penyeliaan kerja pembinaan di tapak	<ul style="list-style-type: none"> ● Model pembinaan Arkitek, Struktur, Mekanikal, Elektrik dan Sivil
		√	Mengurangkan percanggahan dan kesilapan pembinaan	<ul style="list-style-type: none"> ● Laporan koordinasi rekabentuk dan Clash Analysis
		√	Membantu penjanaan lukisan	<ul style="list-style-type: none"> ● Lukisan Pembinaan
		-	Membantu verifikasi jadual kerja pembinaan	<ul style="list-style-type: none"> ● Simulasi pembinaan
Serahan (LOD500)	Kontraktor	√	Membantu pengurusan rekod fasiliti	<ul style="list-style-type: none"> ● Model siap bina Arkitek, Struktur, Mekanikal, Elektrik dan Sivil
		√	Membantu penjanaan lukisan	<ul style="list-style-type: none"> ● Lukisan siap bina

SEKSYEN C : PERANAN DAN TANGGUNGJAWAB

HOPT (BIM Manager)

- a) Mengurus strategi pelaksanaan projek BIM serta memastikan ianya mematuhi keperluan prosedur dan piawaian yang ditetapkan.
- b) Memberi kefahaman mengenai strategi dan proses pelaksanaan projek BIM kepada semua stakeholders.
- c) Mengurus dan memantau status pelaksanaan proses kerja.
- d) Mengenalpasti dan menyelesaikan masalah yang berkaitan dengan pelaksanaan BIM.
- e) Mengurus kajian semula keperluan pelanggan dan kesesuaian pembangunan projek berdasarkan model tapak sedia ada dan massing model.
- f) Menyedia dan memantau status dokumen Pra PPPB.

HODT (BIM Coordinator)

- a) Mengurus penyediaan model bagi disiplin masing-masing untuk memastikan ianya mematuhi keperluan prosedur dan piawaian yang ditetapkan.
- b) Menyelaras penyediaan model dan memastikan integriti model berterusan sepanjang pelaksanaan projek.
- c) Mengenalpasti dan menyelesaikan masalah yang berkaitan di peringkat disiplin.
- d) Mengurus data dan penamaan fail sepertimana piawaian yang ditetapkan.
- e) Memastikan penggunaan template penyediaan model yang betul.
- f) Menyelaras kajian semula keperluan pelanggan dan kesesuaian pembangunan projek bersama HOPT berdasarkan model tapak sedia ada dan massing model.
- g) Menyelia penilaian teknikal ke atas BIM deliverables yang dikemukakan oleh petender bagi tujuan kelulusan dan pembayaran.

HODT (BIM Modeler)

- a) Menyedia dan menganalisis model tapak sedia ada (Sivil sahaja).
- b) Menyedia dan menganalisis massing model dan kesesuaian tapak (Arkitek sahaja).
- c) Melaksanakan kajian semula keperluan pelanggan dan kesesuaian pembangunan projek bersama HOPT berdasarkan model tapak sedia ada dan massing model.
- d) Menganggar kuantiti bahan binaan berdasarkan jadual keluasan lantai (Ukur Bahan sahaja).
- e) Menjalankan penilaian teknikal ke atas BIM deliverables yang dikemukakan oleh petender bagi tujuan kelulusan dan pembayaran.

WAKIL P.D

- a) Menjalankan audit pemeriksaan/pematuhan dan semakan ke atas BIM deliverables yang dikemukakan oleh kontraktor bagi tujuan kelulusan dan pembayaran.
- b) Mengenalpasti dan menyelesaikan masalah yang berkaitan dengan pelaksanaan BIM.
- c) Memastikan dokumen PPPB dikemaskini dan dipatuhi oleh kontraktor.

SEKSYEN D : PROSES KERJA BIM (Fasa Perancangan sahaja)

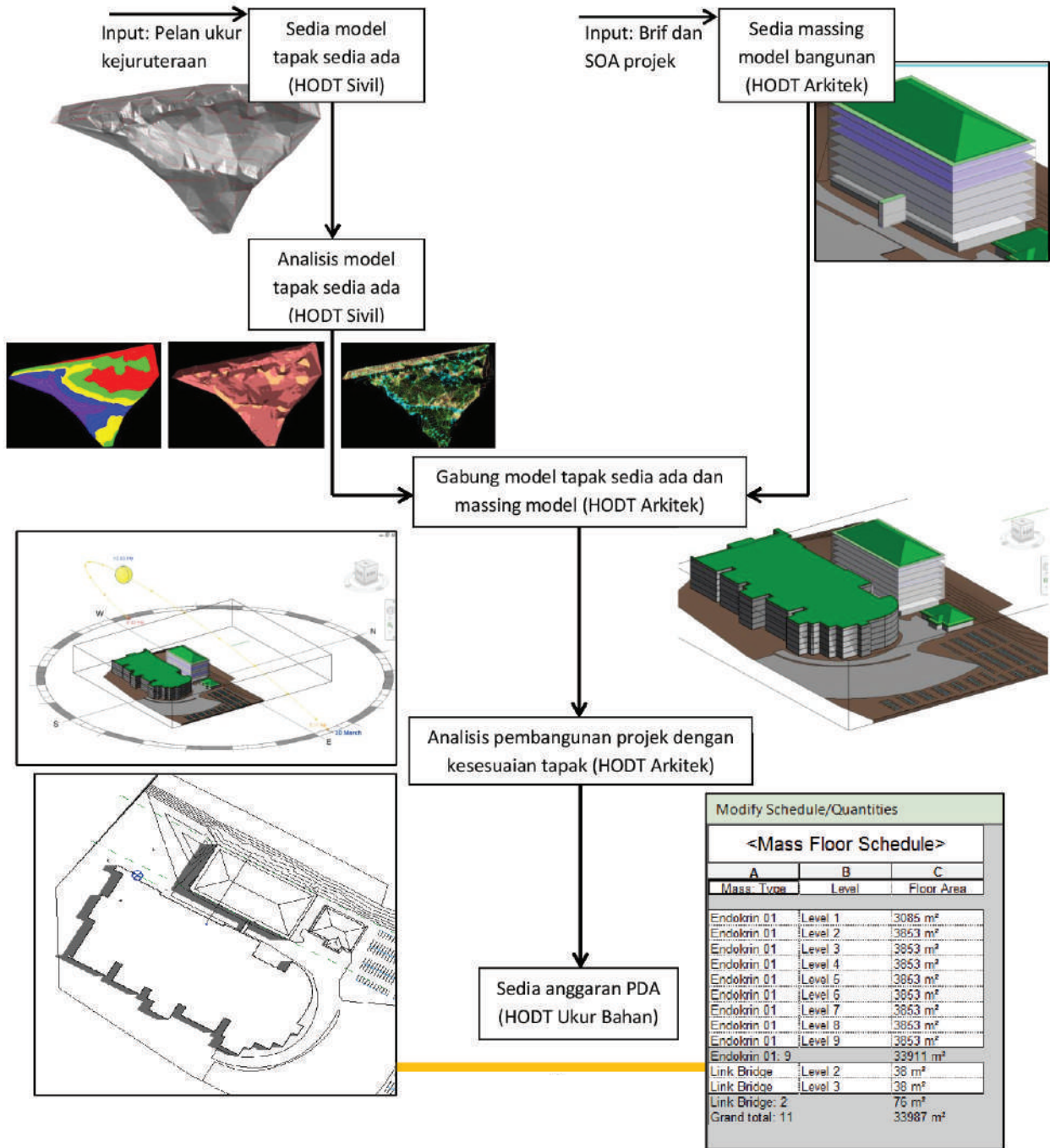

SEKSYEN E : PENGURUSAN KOORDINASI DAN KOLABORASI

Level of Development (LOD) : 100

Kaedah Perkongsian Fail : eCOMs/BIM360/Vault

Penyediaan Dan Perkongsian Fail Model Bagi Tujuan Penyerahan Dan Kelulusan

PERKONGSIAN MAKLUMAT	PEMBERI FAIL	PENERIMA FAIL	FAIL	PERISIAN	FORMAT FAIL ASAL	PERTUKARAN FORMAT FAIL
Analisis tapak – Rekabentuk konsep & Kajian rekabentuk konsep	Sivil	Arkitek	Model tapak	Civil 3D - Revit	.dwg	.rvt
			Laporan analisis tapak	Civil 3D - Acrobat	.Pdf	.Pdf
Rekabentuk konsep – Anggaran Kuantiti		Ukur Bahan, Mekanikal & Elektrik	Massing Model	Revit –Excel	.rvt	.exc
			Jadual keluasan lantai	Revit - Excel	.rvt	.exc

Prosedur Komunikasi Elektronik

File cabinets and baskets	
Projek	
Kategori Bangunan	
Jenis Bangunan	
Kategori Folder	
Pasukan Projek/Disiplin	
Jenis Fail	

SEKSYEN F : STRUKTUR PENAMAAN FAIL

Struktur Penamaan Fail Model:

NAMA FOLDER PROJEK :	
<Kategori Projek>_<Kod Projek>_<Nama Projek>	
FORMAT NAMA FAIL UNTUK MODEL SEPERTI BERIKUT :	
<Tarikh & Semakan Kemajuan>_< Versi Fail Projek, Disiplin & Fasa Projek>_< (Kategori bangunan)_<No.Projek>_<Zon / Blok Bangunan / Tapak>_<Jenis Model>_<Jenis Fail>	
MODEL ARKITEK	
MODEL SIVIL	
FORMAT NAMA FAIL UNTUK LUKISAN SEPERTI BERIKUT :	
<Kod Disiplin & Versi Perisian & Fasa Projek & Penggunaan Dokumen >_ (<Kategori Bangunan>_<Kod Projek>)_<Zon / Blok Bangunan / Tapak>_<Jenis Lukisan>_(<Tarikh & Semakan Kemajuan>).<Format Fail>	
LUKISAN ARKITEK	
FORMAT NAMA LAIN-LAIN FAIL BERKAITAN :	
<Tarikh penerimaan>_<Kod Disiplin & Versi Perisian & Fasa Projek> space<Deskripsi>	
Pra Pelan Pelaksanaan Projek BIM	
Jadual Pelaksanaan	
Laporan Kajian Rekabentuk Konsep (Borang SPB)	

*Nota: Kaedah penamaan fail hendaklah dirujuk kepada dokumen Piawaian BIM JKR

Struktur Model

Struktur fail model BIM dibahagikan mengikut disiplin dan model

DISIPLIN	MODEL (Sila tandakan ✓)	
Arkitek	✓	Keseluruhan
		Aras
		Zon
		Bahagian
		Ruang
Sivil	✓	Skop
		Zon

Sistem Pengukuran Dan Koordinat

Sistem Metrik dan sistem koordinat GPS.

SEKSYEN G : KEPERLUAN INFRASTRUKTUR TEKNOLOGI

Perisian Dan Rujukan Template

DISIPLIN	PERISIAN	RUJUKAN TEMPLATE	VERSI
Arkitek	Revit	jkr16AR_Template Arkitek.rte	2016
Sivil	Civil 3D	Default Setting	2016

Komputer Dan Perisian:

PERKARA	SPESIFIKASI
Processor	Minimum requirement : Intel® Xeon® Processor E3-1220 v2 (8M Cache, 3.10 GHz) or equivalent.
RAM	32 GB 1600 MHz
Graphics	NVIDIA Quadro K2000
DISK	1TB
OS	Latest version Pro 64 bit
Monitor	Minimum 22" Wide Screen

SEKSYEN H : KEPERLUAN PELAKSANAAN BIM DALAM KONTRAK

PERKARA	KETERANGAN
Perisian	1x perisian (3 tahun)
Perkakasan	1x workstation
Pelan Pelaksanaan Projek BIM (Post contract)	1 Sesi

PELAN PELAKSANAAN PROJEK BIM (FASA PEMBINAAN)

UNTUK PROJEK REKABENTUK
KONVENSSIONAL DALAMAN

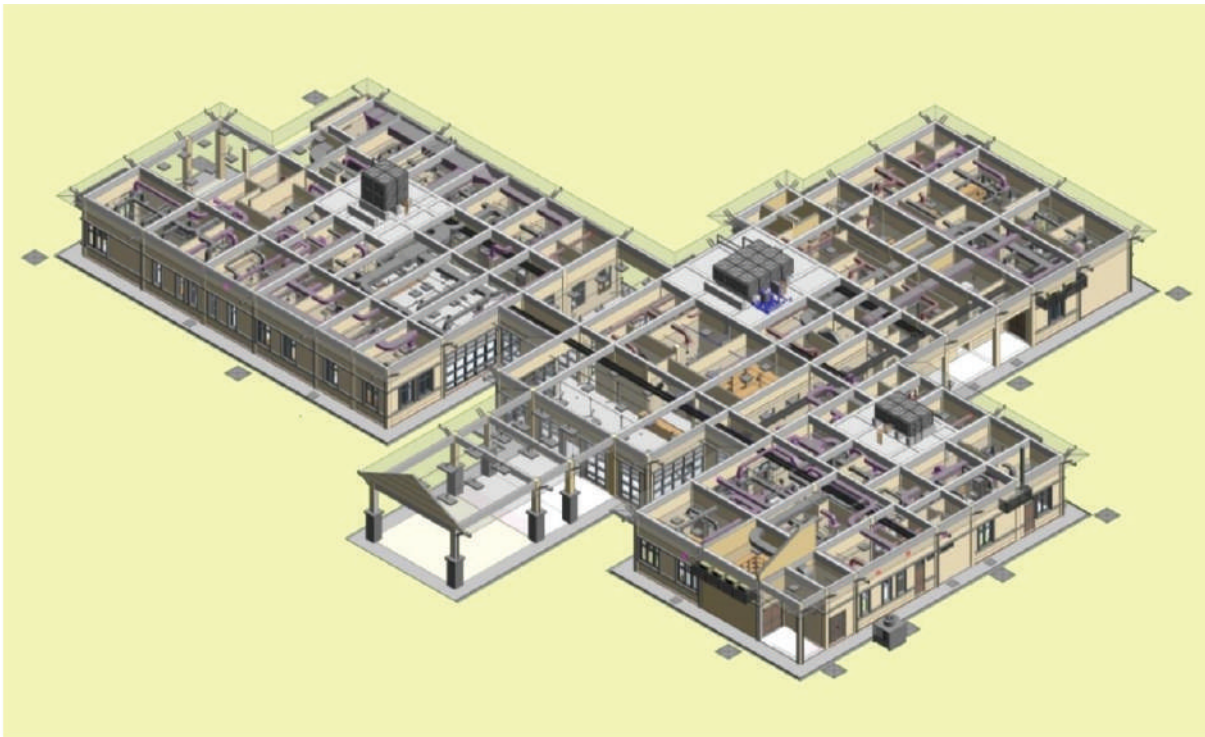

Disediakan : oleh Unit Building Information Modeling (BIM) Cawangan Perancangan
Aset Bersepadu Ibu Pejabat Jabatan Kerja Raya Malaysia

ISI KANDUNGAN

SEKSYEN A: PENGENALAN PELAN PELAKSANAAN PROJEK BIM	2
SEKSYEN B: MAKLUMAT PROJEK	3
SEKSYEN C: SENARAI AHLI PASUKAN	4
SEKSYEN D: OBJEKTIF BIM/KEGUNAAN BIM (BIM USES)	5
SEKSYEN E: FUNGSI ORANISASI/KAKITANGAN	6
SEKSYEN F: PROSES KERJA BIM	8
SEKSYEN G: PERKONGSIAN MAKLUMAT DAN BIM DELIVERABLES	10
SEKSYEN H: KEPERLUAN DATA BIM	10
SEKSYEN I: PROSEDUR KOLABORASI	11
SEKSYEN J: KAWALAN KUALITI	13
SEKSYEN K: KEPERLUAN INFRASTRUKTUR TEKNOLOGI	14
SEKSYEN L: STRUKTUR MODEL	15

SEKSYEN A : PENGENALAN PELAN PELAKSANAAN PROJEK BIM (PPPB)

Bagi menjayakan pelaksanaan Building Information Modeling (BIM) dalam fasa pembinaan projek, Unit BIM telah membangunkan Pelan Pelaksanaan Projek BIM (PPPB) Fasa Pembinaan secara terperinci.

PPPB mengandungi rangka kerja pelaksanaan kaedah BIM dalam sesebuah projek yang akan dijadikan sebagai panduan bagi membolehkan semua pihak terlibat di dalam pelaksanaan projek dapat menggunakan dan memanfaatkan sepenuhnya teknologi BIM. Kriteria PPPB adalah seperti berikut:

- a) Dokumentasi pelan perancangan terperinci kaedah pelaksanaan BIM dalam sesebuah projek yang mengandungi kaedah pemantauan dan kawalan.
- b) Rujukan utama dalam pengurusan data serta penugasan peranan dan tanggungjawab semua pihak.
- c) Mengandungi maklumat penting berkaitan projek dan setiap maklumat tersebut hendaklah dikemaskini dari masa ke semasa. Ia melibatkan kerjasama dan kolaborasi semua pihak yang terlibat di dalam projek.

Secara amnya, pembangunan PPPB dapat membantu dalam:

- a) Memberikan kefahaman yang lebih jelas berkenaan maklumat pelaksanaan kaedah BIM bagi sesuatu projek
- b) Memberikan kefahaman tentang peranan dan tanggungjawab setiap ahli pasukan bagi pembangunan model di setiap fasa
- c) Mengenalpasti BIM deliverables dan tahap keperincian model yang perlu dihasilkan supaya dapat memenuhi objektif projek yang ditetapkan.
- d) Mengenalpasti keperluan sumber manusia.
- e) Mengenalpasti sebarang penambahan keperluan kontraktual kepada Kontrak sedia ada.

SEKSYEN B : MAKLUMAT PROJEK

Pemilik Projek :
 Nama Projek :
 Lokasi Projek :
 Kaedah Pelaksanaan Projek :
 Brif Projek/Skop :
 Skop BIM :
 No. Rujukan Fail BIM :
 Rujukan Projek

MAKLUMAT PROJEK	
Rujukan SKALA	
No. Kontrak	
Kos Projek	
Tarikh Milik Tapak	
Tarikh Slap Semasa	
Perakuan Baiki Kecacatan	
HOPT	
Wakil S.O	
Kontraktor	

Jadual dan Fasa/Milestone Penerimaan Dokumen

FASA/MILESTONE	TARIKH JANGKA TERIMA	PIHAK TERLIBAT
Lukisan Pembinaan Arkitek		
Lukisan Pembinaan Struktur		
Lukisan Pembinaan Mekanikal		
Lukisan Pembinaan Elektrik		
Model NSC Mekanikal		
Lukisan NSC (Shop drawing) Elektrik		
Lukisan Kekuda Bumbung		
Rekod ujian bahan		
Rekod Pembinaan		
Jadual program kerja kontraktor		
Rekod Pengujian dan Pentauliahan (T&C)		
Lukisan Siap Bina (Bangunan)		
Lukisan Siap Bina (Tapak)		

SEKSYEN B : SENARAI AHLI PASUKAN PROJEK

MAKLUMAT PROJEK	NAMA	LOKASI	E-MAIL (@JKR.GOV.MY)	TELEFON
Head of Project Team (HOPT)				
Pengurus Projek				
Pen. Pengurus Projek				
Wakil Pegawai Penguasa				
Pengurus Pembinaan				
Pengurus Tapak				
Head of Design Team (HODT) – Arkitek				
Pengurus Rekabentuk				
Penyelia Rekabentuk				
Perekabentuk				
Head of Design Team (HODT) - Struktur				
Pengurus Rekabentuk				
Penyelia Rekabentuk				
Perekabentuk				
Head of Design Team (HODT) - Awam				
Pengurus Rekabentuk				
Penyelia Rekabentuk				
Perekabentuk				
Head of Design Team (HODT) - Elektrik				
Pengurus Rekabentuk				
Penyelia Rekabentuk				
Perekabentuk				
Head of Design Team (HODT) - Mekanikal				
Pengurus Rekabentuk				
Penyelia Rekabentuk				
Perekabentuk				
Unit Building Information Modeling (BIM) - Fasilitator				
BIM Manager				
BIM Coordinator				
BIM Modeler (AR)				
BIM Modeler (ST)				
BIM Modeler (EL)				
BIM Modeler (ME)				
BIM Modeler (AW)				

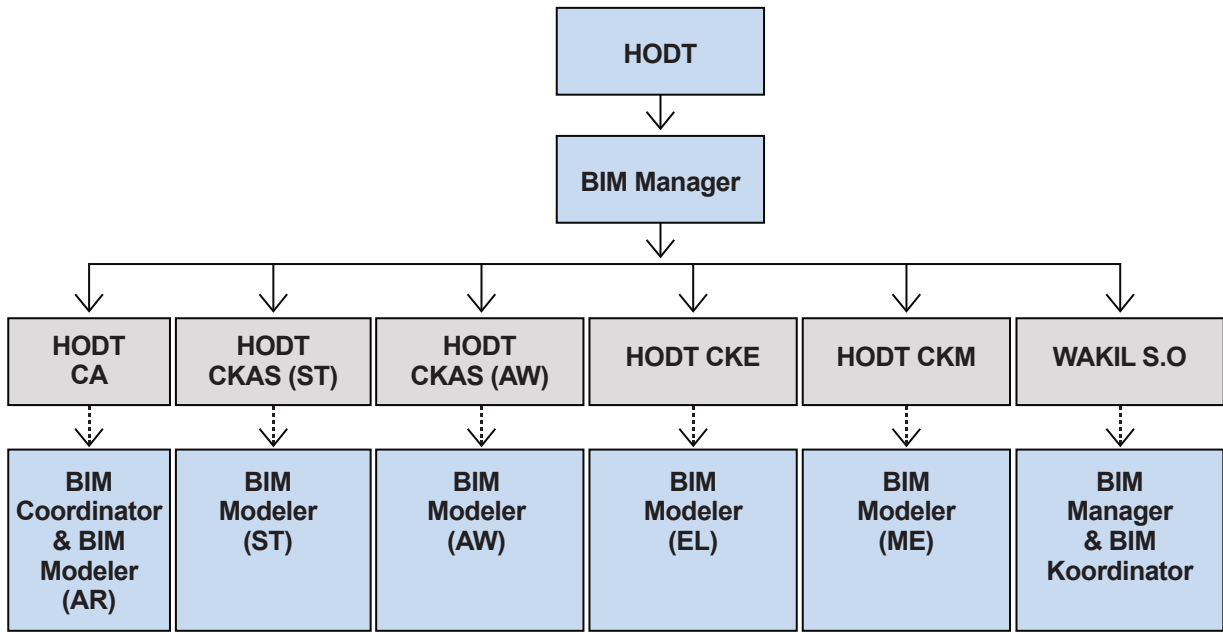

Carta Organisasi Pasukan Proyek

SEKSYEN D:OBJEKTIF BIM/ KEGUNAAN BIM (BIM USES)

1. MATLAMAT UTAMA BIM / OBJEKTIF

Matlamat / Objektif	Kegunaan BIM
Memudahkan kajian rekabentuk	Existing conditions modeling, Design authoring Site analysis, Other engineering analysis, Structural analysis, Design review & 3D coordination
Mengurus kehendak pelanggan melalui visualisasi 3D	Design review
Mengurangkan percanggahan rekabentuk dan kerja berulang di tapak bina	Design review & 3D coordination
Menjana dokumentasi lukisan pembinaan yang dikoordinasi	Design authoring, Design review & 3D coordination
Mengesahkan jadual kerja kontraktor	Phase planning (4D modeling)
Memudahkan pengurusan rekod fasiliti menerusi penyediaan model siap bina	Existing conditions modeling, Design authoring & Record modeling

2. KEGUNAAN BIM :

	Perancangan	Rekabentuk		Pembinaan		Serahan
	Site Analysis	Design Authoring	X	Design Authoring	X	Record Modeling
	Design Authoring	Design Review	X	Design Review	X	Existing Conditions Modeling
	Design Reviews	3D Coordination	X	3D Coordination		
	Existing Conditions Modeling	Existing Conditions Modeling	X	Record Modeling		
	Site Analysis		X	Phase Planning		

SEKSYEN E : FUNGSI ORGANISASI/ KAKITANGAN

1. FUNGSI DAN TANGGUNGJAWAB :

BIM Manager (HOPT/Wakil S.O)

- a) Mengurus strategi pelaksanaan projek BIM serta memastikan ianya mematuhi keperluan dan prosedur Garis Panduan dan Piawaian BIM JKR
- b) Memberi kefahaman mengenai strategi pelaksanaan projek BIM kepada stakeholders
- c) Menyelaras penyediaan model setiap disiplin dan memastikan akaunabiliti dan integriti model berterusan sepanjang pelaksanaan projek
- d) Menyedia dan memantau Pelan Pelaksanaan Projek BIM
- e) Mengurus penyediaan komponen families dan model
- f) Memantau pengurusan data fail, penamaan fail dan template mengikut Piawaian BIM JKR
- g) Mengenalpasti dan menyelesaikan masalah berkaitan pelaksanaan BIM
- h) Mengetuai pelaksanaan projek dan menajdi pemudahcara di antara semua stakeholders

BIM Coordinator (Wakil Pegawai Penguasa Pakar

- a) Mengurus pengemaskinian model bagi memastikan ianya mematuhi keperluan prosedur dan piawaian yang ditetapkan disamping mengekalkan integriti model sepanjang fasa pembinaan
- b) Mengurus data dan penamaan fail sepertimana piawaian yang ditetapkan
- c) Mengenalpasti dan menyelesaikan masalah yang berkaitan di peringkat disiplin
- d) Memastikan integriti model berterusan sepanjang fasa pembinaan
- e) Mengenalpasti tahap keperincian atau Level of Detail (Lod) setiap komponen yang diperlukan semasa fasa pembinaan sehingga fasa serahan

BIM Coordinator (Pegawai Tapak Bina)

- a) Mengurus persembahan model BIM kepada ahli pasukan projek di tapak semasa mesyuarat-mesyuarat yang berkaitan
- b) Mengenalpasti dan menyelesaikan masalah yang berkaitan dengan model semasa fasa pembinaan
- c) Mengurus data dan penamaan fail sepertimana piawaian yang ditetapkan
- d) Membantu BIM Manager menyedia dan memantau status PPPB
- e) Memantau penyediaan model 4D yang disediakan oleh kontraktor

BIM Modeler (HODT/Wakil S.O)

- a) Menyediakan komponen Revit Families
- b) Menyedia dan mengemaskini model disiplin masing-masing dari masa ke semasa
- c) Memastikan akauntabiliti dan integriti model berterusan sepanjang pelaksanaan projek
- d) Melaksanakan clash analysis di peringkat disiplin
- e) Menyediakan rekabentuk dan lukisan pembinaan
- f) Mengemukakan rekabentuk dan lukisan pembinaan terkini kepada Unit BIM bagi tujuan penyediaan/pengemaskinian model
- g) Mengemaskini/meminda rekabentuk dan lukisan pembinaan berdasarkan laporan koordinasi rekabentuk dan clash analysis (jika ada)
- h) Menyelesaikan masalah rekabentuk

KONTRAKTOR

- a) Memaklumkan pindaan jadual program kerja kontraktor dan kos pembinaan (jika ada)
- b) Mengemukakan salinan shop drawing (NSC,kekuda bumbung dll) yang disahkan
- c) Memaklumkan sebarang perubahan rekabentuk/pembinaan di tapak (jika ada)
- d) Memaklumkan tarikh pembinaan/pemasangan bahan binaan dan mengemukakan salinan brochure bahan binaan (scan & emel/cloud 360/ecoms) yang berkaitan
- e) Mengemukakan rekod keputusan pengujian dan pentauliahan bahan binaan yang berkaitan

2. PERANAN ORGANISASI / DISIPLIN :

Matlamat / Objektif	Kegunaan BIM	Model	Fasa	Peranan
Memudahkan kajian rekabentuk	Existing conditions modeling, Design authoring, Site analysis, Design review	Model Pembinaan	Pembinaan	HODT
Mengurus kehendak pelanggan melalui visualisasi 3D	Design review			HODT & Wakil S.O
Menjana dokumentasi lukisan pembinaan yang dikoordinasi	Design authoring			HODT
Mengurangkan percanggahan rekabentuk dan kerja berulang di tapak bina	Design review & 3D coordination	Combined Model		HODT & Wakil S.O
Mengesahkan jadual perancangan kerja kontraktor	Phase planning (4D modeling)	Model Simulasi 4D		Wakil S.O
Memudahkan pengurusan rekod fasiliti	Record model	Model Siap Bina		Serahan
Catatan :				

SEKSYEN F: PROSES KERJA BIM

1. CARTA ALIR PROSES PENYEDIAAN MODEL

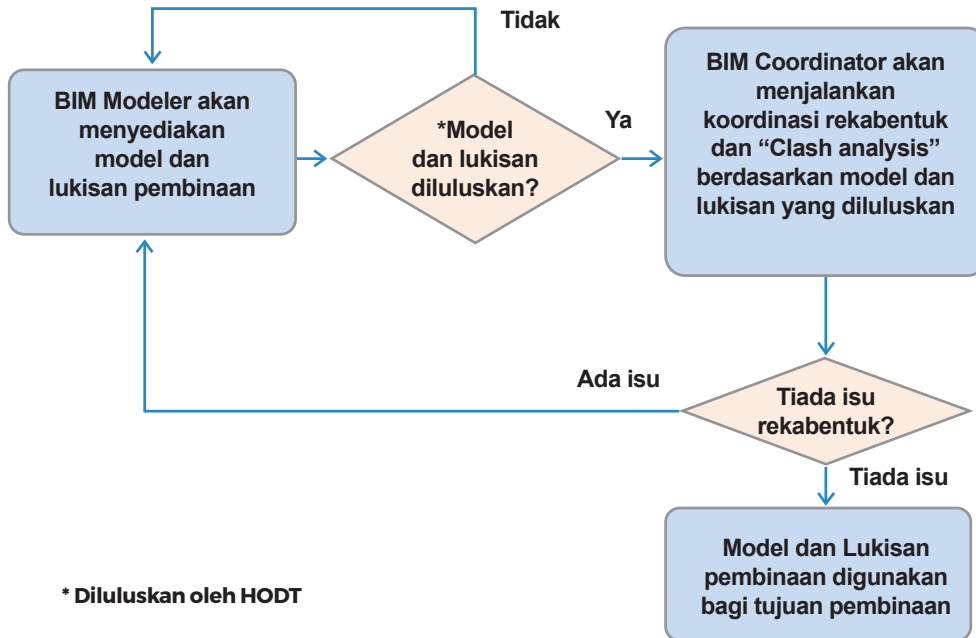

2. CARTA ALIR PROSES PENNGEMASKINIAN MODEL (BERDASARKAN LUKISAN NSC DAN KEKUDA BUMBUNG)

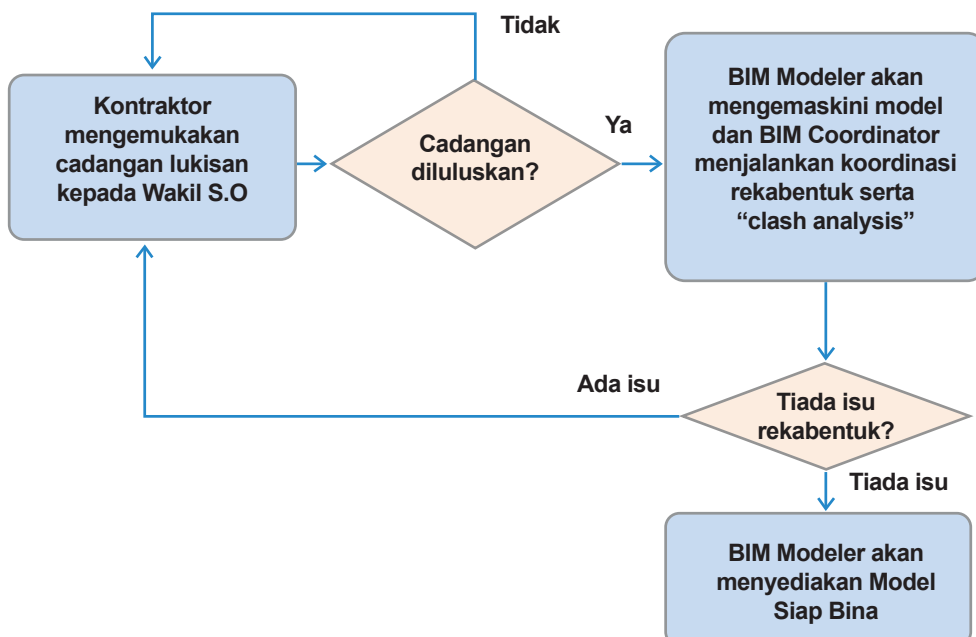

3. CARTA ALIR PROSES PINDAAN MODEL (BERDASARKAN PERUBAHAN LUKISAN DAN PEMBINAAN DI TAPAK)

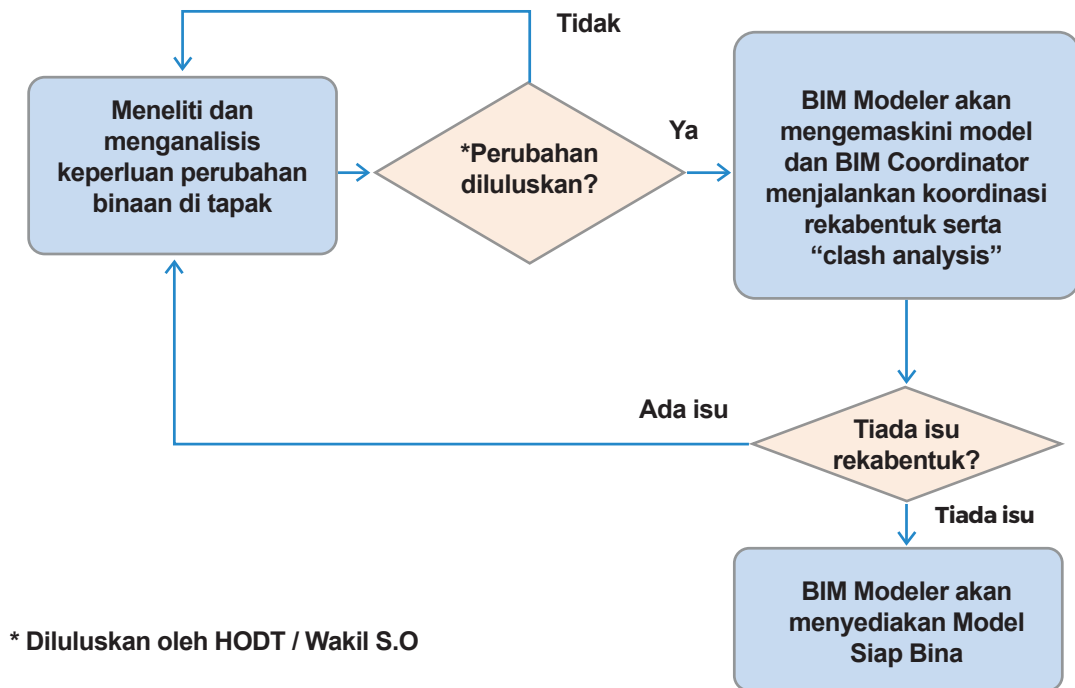

4. CARTA ALIR PROSES PENGISIAN MAKLUMAT ASET

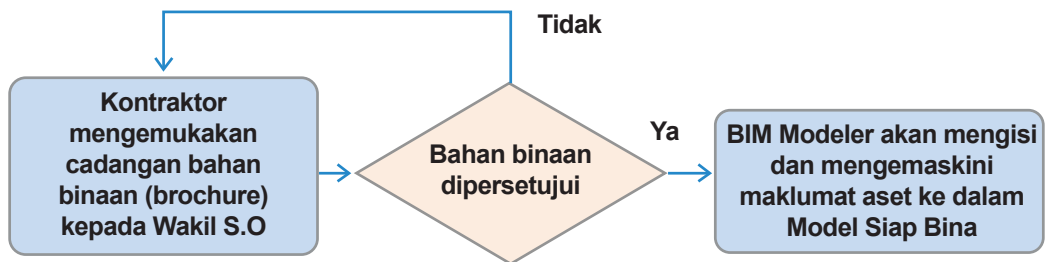

SEKSYEN G : PERKONGSIAN MAKLUMAT DAN BIM DELIVERABLES

1. JADUAL PENYEDIAAN DAN PERKONGSIAN FAIL MODEL :

Jenis Kolaborasi	Penyediaan Fail Model			Penerimaan Fail Model		
	Penyedia	Perisian	Format	Penerima	Perisian	Format
Design authoring - Drawing production	HODT	Revit	* .rvt	HODT	Revit	* .dwfx
Design authoring-3D coordination	HODT	Revit	* .rvt	HODT	Navisworks	* .nwf & * .nwd
Structural analysis - Design authoring	HODT	Orion	* .clx	HODT	Revit	* .rvt
Design authoring- Design review	HODT	Revit	* .rvt	HODT	Navisworks	* .nwf & * .nwd
Design authoring- Phase planning (4D modeling)	HODT	Revit	* .rvt	Wakil S.O	Navisworks	* .nwf & * .nwd
	Kontraktor	MS Project	* .mpp			

SEKSYEN H: KEPERLUAN DATA BIM

1. Semua model hendaklah dilengkapi dengan maklumat teknikal dan spesifikasi rekabentuk.
2. Semua model yang dibangunkan hendaklah berpandukan lukisan pembinaan dan shop drawing yang telah diluluskan
3. Semua maklumat yang perlu dimasukkan di dalam model BIM hendaklah mengikut keperluan “Penjadualan Atribut Teknikal untuk Daftar Aset Khusus (Bangunan)” yang disediakan oleh Bahagian Perundingan Pengurusan Aset (BPPA) CPAB untuk tujuan rekod model bagi kegunaan pengurusan aset dan fasiliti.

SEKSYEN I : PROSEDUR KOLABORASI

2. STRATEGI KOLABORASI

- a) Kaedah komunikasi - Melalui eCOMs, emel, surat dan telefon.
- b) Pengurusan dokumen dan reod - Fail khas projek disediakan dan disimpan di dalam server Unit BIM yang mengandungi data model BIM. Subfail diwujudkan di dalam fail khas projek megikut disiplin dan seterusnya dibahagikan seperti berikut:
- Work in Progress (WIP) - Data aktif yang masih dalam proses model dan rekabentuk
 - Shared - Data yang telah siap, disemak dan diverifikasi mengikut piawai BS 1192:2007 Collaborative
 - Production of Architectural, Engineering and Construction Information oleh setiap disiplin untuk dikongsi bersama disiplin lain bagi tujuan koordinasi
 - Published - Data yang telah disemak, dilulus dan disahkan oleh setiap disiplin bagi tujuan kelulusan pelanggan, dokumentasi perolehan dan pembinaan di tapak
 - Archived - Data yang telah siap dikemaskini dan diluluskan oleh setiap disiplin di peringkat serahan dan disimpan sebagai rujukan bagi tujuan penyelenggaraan

Nama Projek

- 01 Architect
 - 01 WIP
 - 01 CAD
 - 02 BIM
 - 03 Sheet Files
 - 04 Analysis & Design
 - 05 Families
 - 02 Shared
 - 01 CAD
 - 02 BIM
 - 03 Coord Models
 - 03 Published
 - 01 CAD
 - 02 BIM
 - 04 Archived
 - 01 CAD
 - 02 BIM
 - 05 Incoming
 - 06 Resources
- 02 Structure
- 03 Electrical
- 04 Mechanical
- 05 Civil
- 06 Quantity Surveyor

3. KEPERLUAN MESYUARAT/LAWATAN TAPAK :

Mesyuarat	Agenda	Kekerapan (Minimum)	Kehadiran	Lokasi
Mesyuarat Teknikal BIM	<ol style="list-style-type: none"> 1. Penyelarasan lukisan dan model pembinaan 2. Koordinasi rekabentuk 3. Clash Analysis 			
Lawatan Tapak	<ol style="list-style-type: none"> 1. Semakan lukisan dan model pembinaan 2. Pengemaskinian rekod model 3. Pengemaskinian Model 4D 4. Model review 5. Perbincangan isu pembinaan (jika ada) 			

4. PROSEDUR KOMUNIKASI ELEKTRONIK :

Lokasi fail	Nama Folder & Disiplin	Penyelarasan fail
\\ecom\sbim\arkitek	Arkitek	
\\ecom\sbim\struktur	Struktur	
\\ecom\sbim\mekanikal	Mekanikal	
\\ecom\sbim\elektrik	Elektrik	
\\ecom\sbim\sivil	Sivil	
\\ecom\sbim\koordinasi	Koordinasi	

Projek	Kategori Bangunan	Jenis Bangunan	Kategori Folder (Sila Pilih)	Pasukan Projek/Disiplin (Sila Pilih)	Jenis Fail (Sila Pilih)	Nama Fail	Disimpan Oleh
Klinik Kesihatan Maran, ...	BM-Kesihatan	Klinik Kesihatan	02 SHARED	03 Struktur	BIM	jr13st_k_kk_12_0001_1_Sta_ww...	831005015269
Klinik Kesihatan Maran, ...	BM-Kesihatan	Klinik Kesihatan	02 SHARED	03 Struktur	BIM	jr13st_k_kk_12_0001_1_Sta_ww...	831005015269
Klinik Kesihatan Maran, ...	BM-Kesihatan	Klinik Kesihatan	02 SHARED	05 Elektrik	BIM	2015-10-05e_jkr15EL-3_(BMkk5a...	831005015269
Klinik Kesihatan Maran, ...	BM-Kesihatan	Klinik Kesihatan	02 SHARED	04 Mekanikal	BIM	2015-03-19_jkrME15-6_(BMkk5a...	831005015269
Klinik Kesihatan Maran, ...	BM-Kesihatan	Klinik Kesihatan	02 SHARED	04 Mekanikal	BIM	2015-03-19_jkrME15-4_(BMkk5a...	831005015269
Klinik Kesihatan Maran, ...	BM-Kesihatan	Klinik Kesihatan	02 SHARED	04 Mekanikal	BIM	2014-11-19_jkrME15-3_(BMkk5a...	831005015269
Klinik Kesihatan Maran, ...	BM-Kesihatan	Earthwork	02 SHARED	06 Sivil	BIM	2015-03-04e_jkr15C3D-3_(BMkk5...	831005015269
Klinik Kesihatan Maran, ...	BM-Kesihatan	Klinik Kesihatan	02 SHARED	01 Penguru...	PPPB	2015-10-15_jkrPP10-1 PPPB KK5 ...	831005015269
Klinik Kesihatan Maran, ...	BM-Kesihatan	Klinik Kesihatan	02 SHARED	02 Arkitek	BIM	jrAR15_k_kk_12-0001_1-ARa1_w...	831005015269
Klinik Kesihatan Maran, ...	BM-Kesihatan	Klinik Kesihatan	02 SHARED	02 Arkitek	BIM	jrAR13_k_kk_12-0001_1-ARa1_w...	831005015269

SEKSYEN J : KAWALAN KUALITI

1. STRATEGI KESELURUHAN

Kualiti model dikawal dari semasa ke semasa berpandukan semakan kualiti seperti di bawah:

Semakan	Ulasan	Pihak bertanggungjawab	Perisian	Kekerapan
Visual	Untuk memastikan model yang dibina mengikut rekabentuk yang ditetapkan	HODT	Revit, Civil 3D & Navisworks	Minimum 1x /bulan
Konflik/ Percanggahan	Untuk mengenalpasti konflik/ percanggahan antara komponen semua disiplin	HODT	Revit & Navisworks	Minimum 1x /bulan
Piawai	Untuk memastikan model yang dibina memenuhi keperluan piawaian yang ditetapkan	HODT	Revit & Civil 3D	Minimum 1x /bulan
Integriti model	Untuk memastikan integriti model dikekalkan sepanjang tempoh bagi setiap fasa projek	HODT	Revit & Navisworks	Minimum 1x /bulan
Simulasi pembinaan	Untuk memastikan kemajuan kerja di tapak dapat dipantau dengan lebih efektif secara visual	Wakil S.O	Navisworks	Minimum 1x /bulan

2. HAD PENERIMAAN MODEL :

Had terima / toleransi dimensi model hendaklah menepati keperluan analisis, rekabentuk dan pembinaan.

SEKSYEN K : KEPERLUAN INFRASTRUKTUR TEKNOLOGI

1. PERISIAN:

Kegunaan BIM	Pihak Terlibat	Perisian	Versi
Existing conditions modeling	Awam	Civil 3D	
Site analysis	Awam	Civil 3D	
Design authoring	Arkitek, Struktur, Mekanikal & Elektrik	Revit	
	Awam	Civil 3D	
Design review	Arkitek, Struktur, Mekanikal & Elektrik	Revit, Navisworks & Design Review	
	Awam	Civil 3D	
3D coordination	Arkitek, Struktur, Mekanikal & Elektrik	Revit & Navisworks	
Phase planning	Wakil S.O	Navisworks	
Record model	Arkitek, Struktur, Mekanikal & Elektrik	Revit	
	Awam	Civil 3D	

2. KOMPUTER DAN PERISIAN:

Keperluan perkakasan komputer bagi kegunaan perisian BIM adalah seperti di bawah:

Kegunaan BIM	Spesifikasi
Processor	Minimum requirement : Intel® Xeon® Processor E3-1220 v2 (8M Cache, 3.10 GHz) or equivalent.
RAM	32 GB 1600 MHz
Graphics	NVIDIA Quadro K2000
Disk	1TB
OS	Latest version Pro 64 bit
Monitor	Minimum 22" Wide Screen

SEKSYEN L : STRUKTUR MODEL

1. STRUKTUR PENAMAAN FAIL :

Format Nama Fail Model Pembinaan	
Tarikh_Kod Disiplin & Versi Perisian-Fasa_(Kategori Bangunan_Tahun_Indeks)_Zon_Model_(Stand Alone)	
Model Arkitek	
Model Struktur	
Model Mekanikal	
Model Elektrik	
Model Koordinasi	
Model Sipil	

2. STRUKTUR MODEL :

Struktur fail model BIM setiap disiplin dibahagikan mengikut sistem atau zon

Model Pembinaan	Struktur Model
Model Arkitek	Keseluruhan
Model Struktur	Keseluruhan
Model Mekanikal	Sistem
Model Elektrik	Sistem
Model Kejuruteraan Awam	Skop kerja
Model Koordinasi	Disiplin

3. SISTEM PENGUKURAN DAN KOORDINASI

Sistem Metrik dan sistem koordinat GPS

4. RUJUKAN :

- Garis Panduan BIM JKR dan Piawaian BIM JKR

*BPEP ini perlu di sesuaikan dengan jenis dan keperluan projek
Perlu penambahbaikan dari masa ke semasa*

SECTION 4

APPENDIX SDP PROJECT EXECUTION PLAN

SIME DARBY PROPERTY
BUILDING INFORMATION MODELLING
(hereinafter referred to as “BIM”)
PROJECT EXECUTION PLAN
(hereinafter referred to as “PEP”)

This template is provided to assist in the development of a BIM PEP as required in Sime Darby Property Terms of Reference (TOR). A comprehensive guide and details can be found further in this documentation, and should be read either in conjunction with or in advance of completing the enclosed PEP template.

BUILDING INFORMATION MODELLING

PROJECT EXECUTION PLAN

PEP Reference No. : _____

Project Info

Township :
Phase :
Product Type :
No. of Units :

Document Revision History

Version	Date	Description of Changes	Author

1.0 BIM Team Roles and Responsibilities

All consultants and contractors shall perform and execute the services as stipulated in Section 4, Scope of Services of TOR, which with the provision that each consultants and contractors must assign at least one representative as BIM Coordinator in the BIM Team. This is to establish protocol for the BIM modelling process, establish team roles and responsibilities that all parties have agreed upon together.

1.1 The BIM Manager is an agent of the Architect and shall lead the BIM team which is comprised of BIM coordinator from various consultants. The BIM Manager shall lead the BIM process from the pre-design phase onwards to develop and to track the object-oriented BIM against predicted and measured performance objectives, supporting multi-disciplinary building information models that drive analysis, schedules, take-off and logistics. The responsibilities are detailed as, but not limited to the following:

- 1.1.1 Lead, establish and assures development and compliance with BIM PEP.
- 1.1.2 Overall responsibility for the proper use, implementation and deliverables of BIM models conformance with the BIM PEP.
- 1.1.3 Specify and assures no interoperability issues including the core platform, file format and versions.
- 1.1.4 Manage coordination process, provides reports with the identification and/or resolution of hard and soft conflicts coordinate, define, establish file naming structure and file sharing management.
- 1.1.5 Coordinate, facilitates and records BIM related meeting with other discipline BIM coordinator.
- 1.1.6 Assures proper deliverables are met and provided in requirements as specified and agreed in BIM PEP.

At contractor tender award, the BIM Manager will be expected to handover a fully coordinated and complete BIM model to the contractor and the role of the BIM Manager changes from the Architect to the Contractor. In the event that there are multiple main contractors (multi packages), the role of BIM Manager shall stay with the Architect unless otherwise noted.

1.2 The BIM Coordinator shall have the relevant BIM experience and proficiency in the proposed BIM authoring software and should have, as a minimum the following responsibilities for their own disciplines:

(Each consultant is expected to have a BIM Coordinator i.e. Architect, Structural, Mechanical & Electrical, Landscape, Quantity Surveyor etc.)

- 1.2.1 Coordinate technical discipline BIM development, standards and requirements agreed in BIM PEP.
- 1.2.2 Communicates with the Design Team BIM Manager and BIM Team members and acts as the main point of contact for BIM related issues.
- 1.2.3 Responsible for the BIM model creation and information developed as required in BIM PEP.
- 1.2.4 Coordinate with the Design Team BIM Manager and BIM Team members, assures no interoperability issues including the core platform, file format and versions.
- 1.2.5 Coordinate process, provides reports with the identification and/or resolution of hard and soft conflicts coordinate, define, establish file naming structure and file sharing management.

- 1.2.5 Coordinate with the Design Team BIM Manager and BIM Team members, assures no interoperability issues including the core platform, file format and versions.
 - 1.2.6 Coordinate process, provides reports with the identification and/or resolution of hard and soft conflicts coordinate, define, establish file naming structure and file sharing management.
- 1.3 The BIM Modeller shall assist the BIM Coordinator as needed. The numbers of BIM Modeller is depending on the project scale i.e. large projects will required multiple BIM Modeller whereas for a smaller projects, the BIM Coordinator may also act as the BIM Modeller.
- 1.4 Each consultant shall submit BIM Team Organisation Chart and Team Member Curriculum Vitae (CV) as requested through duration of project. In the event of change of person in-charge, the BIM Team Organisation Chart and Team Member CV shall be updated and resubmit to the Client.

SDP reserve the right to instruct the consultant to outsource and engage at consultant own cost a BIM Specialist :-

- 1.4.1 To perform the scope if the consultant fails to perform the task itself;
 - 1.4.2 Identified by SDP if the consultant still fails to outsource and engage one or still fails to perform with its outsourced BIM specialist;
 - 1.4.3 Engaged by SDP if the consultant still fails to perform with above arrangement 1 and 2.
- 1.5 The Consultant BIM Team are expected to still be intact after the BIM model have been handed over to the contractor to fulfil the tasks of:
- 1.5.1 Complying with Sime Darby Property's requirement for design changes, including modelling of changes that occur after tender.
 - 1.5.2 Verifying changes proposed by Contractor's BIM Team, in keeping the design intent intact.
 - 1.5.3 Participating as active members in joint BIM coordination meeting among Contractor, Consultants, Contractor BIM team and the Consultants BIM Team. Minutes of meeting documentation are part of consultant fee claim.
 - 1.5.4
- 1.6 The consultant fee claim shall be paid in accordance to the BIM requirement. The attached Schedule of Payment for consultant's fee (Appendix 1) demonstrate the scope of services and BIM requirement prior to the fee processing for the approval by the client.

Example of BIM Team Organisation Chart :

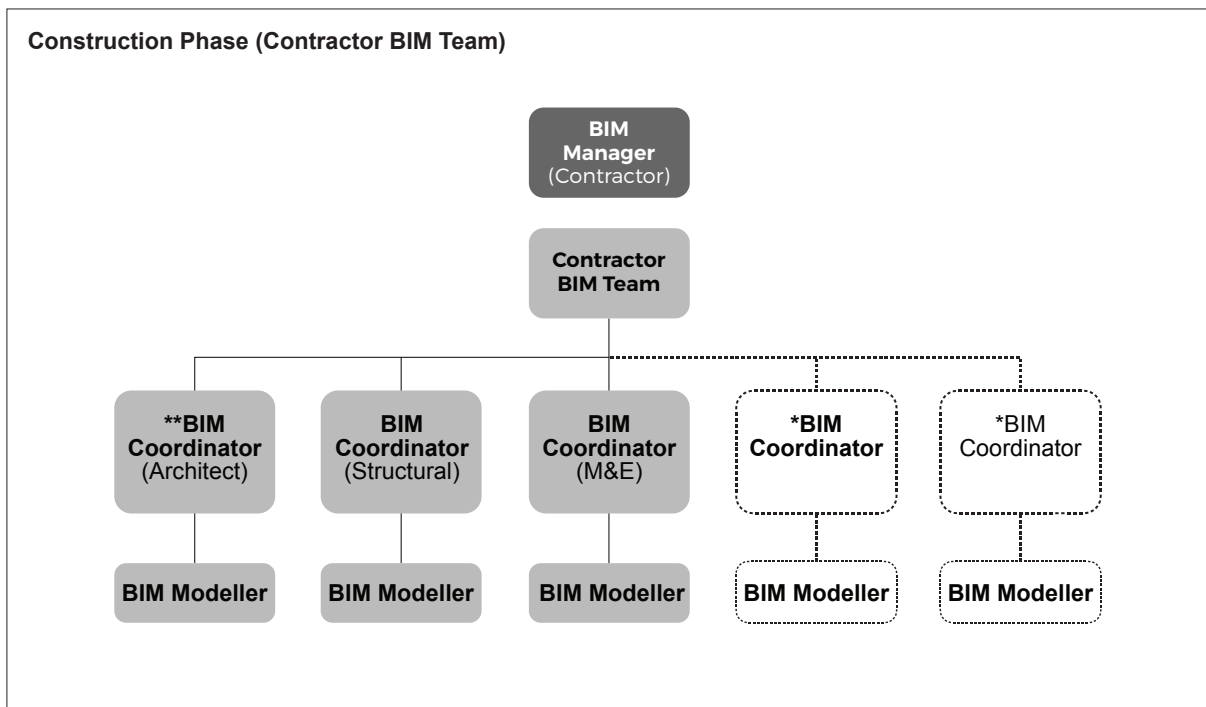
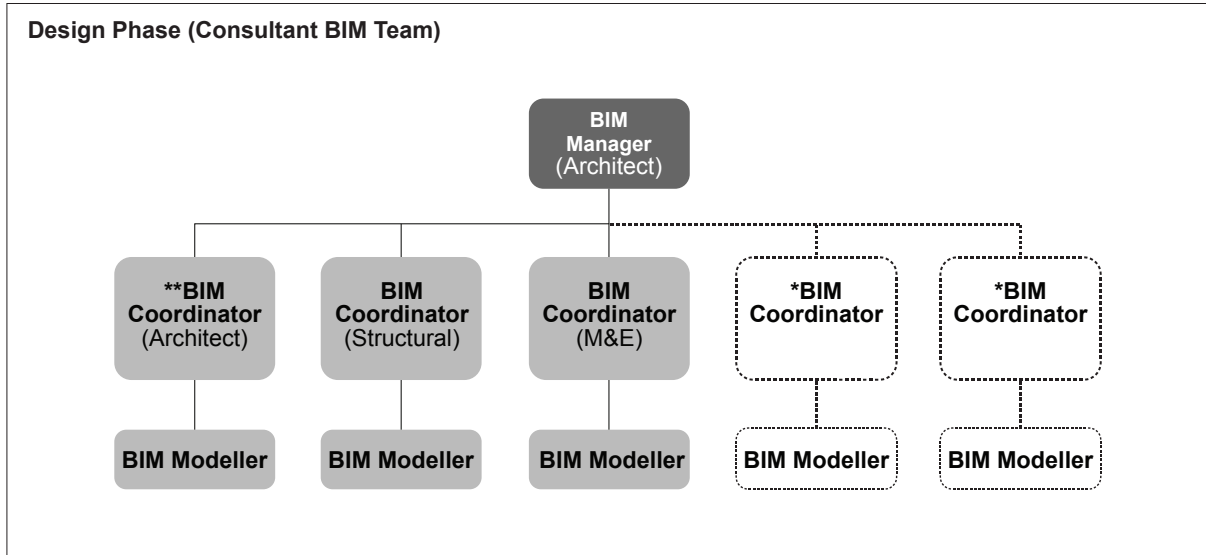

Compulsory



Other related Consultants such as Infrastructure, Landscape, Quantity surveyor, Facade Specialist, etc.

3.0 BIM Use and Deliverables

This section describes the BIM use of BIM model for each phase. Consultants are required to identify the appropriate use of BIM on a project, given the project characteristics and consultants capabilities to achieve the targeted BIM uses.

3.1 Conceptual Design Phase

Activities	Conceptual Design			
LOD	100			
Start				
End				
BIM Uses (/)	Site Analysis			
	Site Planning			
	Conceptual Massing			
BIM Uses				
Site Analysis <ul style="list-style-type: none"> ● Analyse technical factor on site (zoning, infrastructure, regulatory requirements, etc.) 				
Site Planning <ul style="list-style-type: none"> ● Existing site's contour and location should be modelled based on the land surveyor's information (spot levels, boundaries, north-east point, etc.) ● Site model also should take into account:- <ul style="list-style-type: none"> ○ Local authorities' requirement i.e. setback, building plinth, zoning for open green area etc. ○ Plot ratio calculation ○ Area measurement and tabulation ○ Site levels of road, bench platform, surrounding road etc. 				
Conceptual Massing <ul style="list-style-type: none"> ● Concept massing taking into account site context and site analysis. ● Model to show the overall building envelope without the internal elements i.e. internal partition. ● Overall building massing indicative of area, storeys, height, volume, location, orientation and shape. 				

3.2 Schematic Design Phase / KM Building

Activities	Conceptual Design		
LOD	100		
Start			
End			
BIM Uses (/)	Site Planning		Cost Estimation
	Architectural Design		Sustainability Evaluation
	Structural Planning		Visualisation
	MEP Planning		Landscape Design
	3D Coordination		
BIM Uses			
<p>Site Planning</p> <ul style="list-style-type: none"> ● Existing site's contour and location should be modelled based on the land surveyor's information (spot levels, boundaries, north-east point, etc.) ● Site model also should take into account:- <ul style="list-style-type: none"> ○ Local authorities' requirement i.e. setback, building plinth, zoning for open green area etc. ○ Plot ratio calculation ○ Area measurement and tabulation ○ Site levels of road, bench platform, surrounding road etc. 			
<p>Architectural Design</p> <ul style="list-style-type: none"> ● Building elements with nominal dimensions. ● Compliance to SDP's Standard Design and Specification Guidelines. ● Model to contain the layout of overall spaces/rooms. ● Building layout consist of generic building elements without specific attribute data. ● All opening in walls should be shown as general information with the function of windows and doors. ● The model should be able to show general architectural drawing and/or any other addition drawing sufficient for preparing initial cost estimation. ● BIM Model and drawings are ready for PDC presentation 			
<p>Structural Planning</p> <ul style="list-style-type: none"> ● Elements to be modelled with nominal dimensions. ● Compliance to SDP Preferred Structural Sizes. ● Structural system and basic structure as a generic element and material i.e. column and beam, shear wall, etc. ● Coordination of column and beam i.e. no cross beam in major area. 			
<p>MEP Planning</p> <ul style="list-style-type: none"> ● Schematic diagram and equipment symbol to show the entire system distribution. ● Massing/zoning to represent space required for MEP system. ● Each MEP equipment to be modelled using generic object. 			
<p>3D Coordination between Consultants</p> <ul style="list-style-type: none"> ● Building system and components shall be modelled at minimum requirement accurately and in enough detail to be able to run clash detection (design interference) and determine hard and soft clashes. 			
<p>Cost Estimation</p> <ul style="list-style-type: none"> ● Preliminary costing to be based on feasibility studies and measurement of generic elements. 			

Sustainability Evaluation

Lighting Analysis

- Lighting design and performance analysis to be based on geometry, building orientation and generic element.
- Solar radiation analysis

Thermal Analysis

- Passive thermal design strategies
- Overall building thermal analysis to be based on generic element and geometry.

Energy Analysis

- Determine overall energy requirement to be based on generic element and geometry.

Additional use

- Building orientation to be taken into account for maximising natural lighting and ventilation.
- External shading and glare control analysis.

Visualisation

- 3D rendering images of the building in several angles.
Sun path and shadow studies.
- Rendering images of overall development.
- 2D drawings of floor plan, sections and elevations/façade with appropriate colour and line weight.

Landscape Design

- Design concept and layout model.

Consultant Payment Milestones

- Consultant payment milestones throughout the design process will depend on achieving these BIM milestones as stated in Appendix 1
- Consultant required to submit BIM LOD 100 Sign-Off Form (TBC) for Claim Verification.

3.3 BP Documentation

Activities	BP Documentation		
LOD	200		
Start			
End			
BIM Uses (/)	Architectural Design		Structural Analysis
	Structural Design		MEP Analysis
	MEP Design		Sustainability Evaluation
	3D Coordination		Drawings for BP and BOMBA
	Material Take-Off		Scheduling
	Visualisation		
BIM Uses			
<p>Architectural Design</p> <ul style="list-style-type: none"> ● Site plan to show lot size, setback, surface water drainage direction, gridlines and levelling. ● Floor plans to show accurate dimensions, usage of room, area, floor level, surface water drainage direction and complete material specification. ● Section and elevation to show 'floor-to-floor' height, gridlines, façade design and levelling. Colour of finishes which appear on floor plan, elevation and section must be complied with local authorities' standard for Building Plan submission. 			
<p>Structural Design</p> <ul style="list-style-type: none"> ● Structural elements to be updated with actual parameter and material specification. ● Compliance to SDP Preferred Structural Sizes. 			
<p>MEP Design</p> <ul style="list-style-type: none"> ● Sanitary plans to show diagrammatic layout, piping system with standard colour, inspection chamber details and gully trap details. ● System routing should be connected with fittings. ● All cable tray, conduit, etc. shall be connected to the equipment. ● Fittings allowance, cross-over space and maintenance space to be included. 			
<p>3D Coordination between Consultants</p> <ul style="list-style-type: none"> ● Building system and components shall be modelled at minimum requirement accurately and in enough detail to be able to run clash detection (design interference) and determine hard and soft clashes. 			
<p>Material Take-Off</p> <ul style="list-style-type: none"> ● Estimated cost to be based on measurement of actual type of elements and material. 			
<p>Structural Analysis</p> <ul style="list-style-type: none"> ● Determine each structure's intended use, type, size and material properties. ● Determine the integrity of structure to support live loads and dead loads of the building. 			
<p>MEP Analysis</p> <ul style="list-style-type: none"> ● Coordinated service plan, sections, elevation shall be derived from the MEP model i.e. external works, siphonic rainwater, M&E machines and equipment (if applicable). 			

Sustainability Evaluation

Lighting Analysis

- Visual simulation to be based on actual specific building element and actual lighting parameter with lux level.
- Analysis to determine visual comfort in the building space.

Thermal Analysis

- Thermal zone to be determined.
- Calculation of thermal transfer value to be based on overall spaces in the building.
- Design decision to be made based on thermal parameter and equivalent thermal load.

Energy Analysis

- To establish energy target.

Additional use

- Building orientation to be taken into account for maximising natural lighting and ventilation.
- External shading and glare control analysis.

Visualisation

- 3D rendering images of the building in several angles.
- Sun path and shadow studies.
- Rendering images of overall development.
- 2D drawings of floor plan, sections and elevations/façade with appropriate colour and line weight and in accordance to BP submission requirement.

Drawing for BP and BOMBA

- To be prepared as required by the Local Authorities.

Scheduling

- To be prepared as required by the local authorities with sufficient information of the components.
- Schedule of window and door opening for minimum natural ventilation and natural lighting.

Consultant Payment Milestones

- Consultant payment milestones throughout the design process will depend on achieving these BIM milestones as stated in Appendix 1
 - Consultant required to submit BIM LOD 200 Sign-Off Form (TBC) for Claim Verification.

3.4 Tender Documentation

Activities	Tender Documentation		
LOD	300		
Start			
End			
BIM Uses (/)	Architectural Specs. & Detailing		Material Take-Off
	Structural Specs. & Detailing		Scheduling
	MEP Specs. & Detailing		Constructability Analysis
	3D Coordination		
BIM Uses			
<p>Architectural Specifications and Detailing</p> <ul style="list-style-type: none"> ● Model with accurate/critical dimensions. ● Update all the building elements with the actual parameter specification provided by specific supplier. ● To include fittings information i.e. types, materials etc. ● The necessary 2D detail drawings can be generated using BIM authoring software or with assistance of CAD. 			
<p>Structural Specifications and Detailing</p> <ul style="list-style-type: none"> ● Structural elements to be updated with specific parameter and specification to reflect actual type, size, material and performance criteria. ● Joint/connections to be detailed up. ● The necessary 2D detail drawings can be generated using BIM authoring software or with assistance of CAD. 			
<p>MEP Specifications and Detailing</p> <ul style="list-style-type: none"> ● Equipment shall be updated with specific parameter and specification to reflect actual size, material, type code and performance criteria. ● Downward slopes of pipes shall be modelled accurately. ● The necessary 2D detail drawings can be generated using BIM authoring software or with assistance of CAD. 			
<p>3D Coordination between Consultants</p> <ul style="list-style-type: none"> ● Building system and components shall be modelled at minimum requirement accurately and in enough detail to be able to run clash detection (design interference) and determine hard and soft clashes. 			
<p>Material Take-Off</p> <ul style="list-style-type: none"> ● Final costing to be based on confirmed design and ready to issue tender to selected contractor. 			
<p>Structural Analysis</p> <ul style="list-style-type: none"> ● Determine each structure's intended use, type, size and material properties. ● Determine the integrity of structure to support live loads and dead loads of the building. 			
<p>MEP Analysis</p> <ul style="list-style-type: none"> ● Coordinated service plan, sections, elevation shall be derived from the MEP model i.e. external works, siphonic rainwater, M&E machines and equipment (if applicable). 			

Scheduling

- Door/window opening, fittings, products, materials and finishes selected are clearly documented on drawings and in specification.

Coordinated 3D Model Submission

- BIM Manager to hand over complete and fully coordinated 3D model to the client upon completion of tender document together with *BIM LOD 300 Sign-Off Form (TBC).

Constructability Analysis

- Analyse the ease and efficiency in which a building can be built by considering common industry construction practices, availability of material, material sizes, logistics, cost, and environmental constraints. This analysis aims to reduce or prevent errors, delays, and cost overruns during construction.
- Examples to be considered: unique structures, deep basements, link bridges, glazing sizes, common material sizes, site access, & material sourcing.

Consultant Payment Milestones

- Consultant payment milestones throughout the design process will depend on achieving these BIM milestones.

3.5 Construction Phase – Contractor’s Deliverables (FOR REFERENCE ONLY)

Activities	BIM 3D Modelling Coordination & Clash Detection		
LOD	300		
Start			
End			
BIM Uses (/)	3D Coordination		MEP Specs & Detailing
	Clash Detection		BIM Coordination Meeting
	Architectural Specs & Detailing		Constructability Analysis
	Structural Specs & Detailing		3D Model Submission
BIM Uses			
<p>3D Coordination</p> <ul style="list-style-type: none"> The Project shall utilize BIM (Building Information Modelling) for the coordination of selected systems including but not limited too; all Reinforced Concrete Works, Structural Steel, Mechanical, Plumbing, Fire Protection, Telecommunication and Electrical Systems, Interior Walls/Partitions/Finishes and any other systems or trades as may be deemed beneficial by the Owner. 			
<p>Clash Detection</p> <ul style="list-style-type: none"> The Contractor will provide a BIM Manager who shall be qualified in all aspects of BIM modelling and have a minimum of Fifteen (15) years' experience in 3D Modelling (BIM) who will create 3D models, issue clash detection reports and run clash coordination meetings in conjunction with the Contract Administrator. 			
<p>Architectural Specifications and Detailing</p> <ul style="list-style-type: none"> Model with accurate/critical dimensions. Update all the building elements with the actual parameter specification provided by specific supplier. To include fittings information i.e. types, materials etc. The necessary 2D detail drawings can be generated using BIM authoring software or with assistance of CAD. Components shall be drawn in 3D to represent shop drawings and actual construction, not simply as designed by consultants. Further develop consultant model as necessary. 			
<p>Structural Specifications and Detailing</p> <ul style="list-style-type: none"> Structural elements to be updated with specific parameter and specification to reflect actual type, size, material and performance criteria. Joint/connections to be detailed up. The necessary 2D detail drawings can be generated using BIM authoring software or with assistance of CAD. Components shall be drawn in 3D to represent shop drawings and actual construction, not simply as designed by consultants. Further develop consultant model as necessary. 			
<p>MEP Specifications and Detailing</p> <ul style="list-style-type: none"> Equipment shall be updated with specific parameter and specification to reflect actual size, material, type code and performance criteria. Downward slopes of pipes shall be modelled accurately. The necessary 2D detail drawings can be generated using BIM authoring software or with assistance of CAD. Components shall be drawn in 3D to represent shop drawings and actual construction, not simply as designed by consultants. Further develop consultant model as necessary. 			

BIM Coordination Meeting

- The Contractor and subcontractors shall participate in BIM coordination and review meetings conducted by the BIM Manager and attended by the Designers & Contract Administrator.
- It is possible that as a result of the information exchanged during the BIM coordination meetings, the works depicted in the contractor's, subcontractor's 's shop drawing submissions etc. may need to be changed by the contractor and/or subcontractor in order to achieve coordination with other elements of the Project being provided by others.
- Attendance by Consultant BIM Team is compulsory and shall be recorded in BIM Coordination & Clash Detection Sign-Off Form (TBC).

Constructability Analysis

- Analyse the ease and efficiency in which a building can be built by considering common industry construction practices, availability of material, material sizes, logistics, cost, and environmental constraints. This analysis aims to reduce or prevent errors, delays, and cost overruns during construction. Examples to be considered: unique structures, deep basements, link bridges, glazing sizes, common material sizes, site access, & material sourcing.

3D Model Submission

- Unless otherwise noted, the Contractor shall submit complete and fully coordinated 3D model to the client.

4.3 BIM Authoring Software

Function	Software Preferred	Other	Description
Model Creation	Autodesk Revit (Architecture, C&S, MEP) AutoCAD Civil 3D (C&S)	Graphisoft ArchiCAD Tekla Structures Bentley (Vectorworks)	<p>The model creation tool should be built on a database platform that allows for the creation of parametric and information-rich objects. Parametric modelling dependencies should be automatically updated whenever changes are made. The BIM Operator:</p> <ul style="list-style-type: none"> ● Should be able to standardise Project Base Points and Survey Points at 0,0,0 ● Should accommodate file linking, sharing or referencing since a design may come from multiple parties ● Must be capable of producing 2D plans to fulfil contract document deliverable requirements
Model Integration & Clash Detection	Autodesk Revit Naviswork Manage		<p>The model integrator shall be used to combine multiple design files from different software platforms and to be used for clash detections and model simulations.</p> <p>The clash detection tools should be able to do a clash detection analysis and to generate clash detection reports that can be exported into:-</p> <p>*.xls, .csv, or .xml files</p> <p>The simulation tool must allow the user to simulate construction processes over time and allow for real-time walk through. The model integrator should be able to open and combine at least these files types:</p> <p>.dwg, .dwf, .dxf, .sat, .ifc, .dgn, .prp, .prw, .ipt, .iam, .ipf</p> <p>*.rvt, .ifc, .pln, .asm, .prt, .g, .neu, .co, .dgn, .sat, .sdnf, .dgn,</p> <p>** .ifc</p>
Model Visualisation	Naviswork Manage		<ul style="list-style-type: none"> ● The model visualisation software shall be used by project team members who do not need the full functionality of the BIM model creation, integration, or simulation tools. ● The visualisation tool must allow users to simulate the movement of the 3D model.
Model Sequencing	Naviswork Manage		<ul style="list-style-type: none"> ● The 4D model sequencing tool will be used to visualise the scheduled assembly of the building. ● The tool should allow users to visualise the assembly of the building based on scheduling input. It should also integrate with standard scheduling systems such as Microsoft Project or Primavera.

Model Quantity Take-off	Exactal CostX Glodon Microsoft Excel	CostOS Nomitech Autodesk Quantity Takeoff	<ul style="list-style-type: none"> ● The quantity take-off tool shall be used to extract bill of quantities from BIM models for cost-estimating and purchasing purposes. The tool must be able to extract quantities automatically both from 3D and 2D design files. ● The quantity take-off software must be able to integrate with estimating programmes, or the information from the system must be exportable to an .xls, .csv, or .xml file format. The quantity take-off tool must be compatible with the model creation tool listed below in the Collaborative Project Management section.
Collaborative Project Management	Primavera Microsoft Project		<p>The model creation tool should be built on a database platform that allows for the creation of parametric and information-rich objects. Parametric modelling dependencies should be automatically updated whenever changes are made. The BIM Operator:</p> <ul style="list-style-type: none"> ● Be web-based or web-enabled—so all relevant, authorised project team members can access it remotely to accommodate different permissions profiles for different project team members ● Allow communication through either internal messaging or system-generated email ● Include document management capability that lets the project team to create a customised and permission-based folder structure that offers upload, download, and version control capabilities ● Include a viewer that allows the project team to view .dwg, ● .dgn, .plt, .dwf, .pdf, .tif, .jpg, .doc, and .XLS files ● Include construction management capabilities for tracking requests for information (RFIs), submittals, design review, meeting minutes, daily reports, issues, correspondence, and transmittals ● Allow for cost management controls including budgeting, contracting, change orders processing, and payment applications tracking. ● Allow the project team to run reports based on the information in the system
Energy Analysis	Ecotect Green Building Studio IES	Bentley Tas Simulator Design Builder Graphisoft EcoDesigner	<p>The energy analysis should have the ability to be exported to a wide range of BIM program and CAD format to:-</p> <ul style="list-style-type: none"> ● Display and animate complex shadows and reflections ● Generate interactive sun-path diagrams for instant overshadowing analysis ● Calculate the incident solar radiation on a surface ● Calculate heat loads and temperature graphs for any zone
Structural Analysis	Autodesk Robot Structural Analysis Orion	Bentley	<p>The structural analysis tools shall be used to determine the effects of loads on physical structures and their components.</p>

5.0 Project Collaboration Plan

5.1 Reason for using collaboration platform:

- 5.1.1 Collaboration platform consists of cloud-based services and digital workspace for design collaboration which is built around the AES/FM processes supported by IFC.
- 5.1.2 It is crucial for:
- Accessing
 - Storing
 - Conducting
 - Integrating
 - Revising large volume of information throughout project lifecycle.
- 5.1.3 This collaboration platform also emphasises several aspects such as user management, visualisation control, data management, system management and technical support. The Operational technical requirement shall be established by SDP in managing the BIM modelling management and BIM server management by securing all the data consistency and prevent any unauthorised access to the system. SDP shall have a secure server that store BIM libraries. Nominated consultant for projects shall be given authorisation to access to the server throughout project lifecycle.

5.2 Benefits of using project collaboration platform:

- 5.2.1 Virtual database which can be accessed easily anywhere can help users accessing it any time helps in speeding up the project delivery.
- 5.2.2 Allow integration of all the relevant data generated and required by various disciplines involved in a given project.
- 5.2.3 Facilitate design collaboration update, maintenance and retrieval of all data and metadata.
- 5.2.4 Support automated extraction and processing of data or report such as clash detection report, model quantity take-off for costing, area calculation and others.
- 5.2.5 Gives improvement in visualisation and buildability by allowing model integration between different disciplines.
- 5.2.6 Allow standardisation of project base points and survey point in reducing conflicts and coordination errors.
- 5.2.7 Analyse and visualise product performance over the building life cycle.
- 5.2.8 Supports content development for electronic building component objects including product data and links to manufacturer websites.

5.3 Different elements of the collaboration platform:

File naming structure of working files:

Field 1	Field 2	Field 3	Field 4	Field 5	Field 6
PEP Reference No.	Primary Fields	Building Type	Type Variation	Role	Revision
PEP Reference No.	Primary Fields	Building Type	Type Variation	Role	
XX_XXXXX eg : NU_NU4C	CC - Conceptual SC - Schematic BP - BP Submission TR - Tender Drawing CO - Construction	BG - Bungalow SD - Semi Detached TH - Townhouse LH - Link House SL - Super Link CD - Condominium AP - Apartment RT - Retail SA - Service Apartment	C - Corner lot A - Intermediate lot AM - Intermediate mirror A1 - Intermediate different type E - End lot	AR - Architect CS - C&S Engineer ME - M&E Engineer QS - Quantity Surveyor LS - Landscape ID - Interior Design PL - Planner OD - Other Discipline	

5.4 Collaboration Platform

Method of Communication (/)		Descriptions
Email		
Data Storage (Pen drive, CD/DVD, etc.)		
File Transfer Protocol		
Online Project Collaboration		
Web-based storage		
Others (Please specify):		
<p>Collaboration platform consists of cloud-based services and digital workspace for design collaboration which is built around the use of IFC.</p> <p>The examples area as followed:-</p> <p>Simple collaboration:</p> <ul style="list-style-type: none"> • Email • FTP • Others <p>Cloud-based collaboration platform:</p> <ul style="list-style-type: none"> • Autodesk 360 • Aconex • Autodesk Vault • Google Drive • Dropbox • Box • Others <p>Hands-on collaboration :</p> <ul style="list-style-type: none"> • USB Storage • CD/DVD • Others 		

5.5 Meeting Procedures / Project Phase / Milestones

All consultants meeting details including attendances, matter discussed, action and solution to be recorded.

6.0 Ownership of documents and copyright (as per TOR)

- 6.1 The Consultant agrees that all of the intellectual property rights of such distinctive and exclusive concepts, ideas, designs, calculations, drawings, sketches, specifications, proposals, reports, diagrams, data, items, models, materials, as-built drawings and other similar documents in whatever form which are being developed, prepared, formed, produced, adopted or implemented distinctively and exclusively for the Project (“intellectual property rights of the Designs”) shall be transferred to the Client upon full payment of the portion of fees up to the completion of Design
- 6.2 Development Stage (as per TOR) and the Client shall retain all of the intellectual property rights of the Designs.
- 6.3 The Client shall have the right to use or reproduce any of the intellectual property rights belonging to him in whatsoever form and howsoever manner and/or purpose without the prior notification or consent from the consultant.
- 6.4 Parties shall only be entitled to use or reproduce any of the intellectual property rights belonging to the other party for the sole purpose of the Project and for which they are intended and no complete or partial reuse or reproduction of the other party’s intellectual property rights shall be made without the prior written approval of the other party.
- 6.5 The consultant shall indemnify the Client from and against all claims, demands, proceedings, damages, costs, charges, losses (including consequential loss) and expenses whatsoever for or on account of any infringement of any patent rights, design, trademarks or names or other protected rights in respect of any drawings and/or specifications prepared by the Consultant and used for or in connection with the Project and/or Services.
In the event of termination of the agreement, the Client shall have the right to use or reproduce any of the intellectual property rights of the designs, including but not limited to the right to use the 3D models and/or electronic files, for purposes of the Project.

BUILDING INFORMATION MODELLING

We, the undersigned hereby agreed to execute the below mentioned project as per the terms and conditions stipulated in the PEP.

PEP Reference No. : _____

Signature

Name :
Date :
Company Stamp :

Signature

Name :
Date :
Company Stamp :

Signature

Name :
Date :
Company Stamp :

Signature

Name :
Date :
Company Stamp :

Signature

Name :
Date :
Company Stamp :

Signature

Name :
Date :
Company Stamp :

Concurred by (SDP):

Signature

Name :
Date :
Company Stamp :

Signature

Name :
Date :
Company Stamp :

APPENDIX 1 : SCHEDULE OF PAYMENT

	Total Fee	Percentage Area of Work	Cumulative Percentage
a	Upon Appointment	0%	0%
b	Master Plan & Schematic Design Stage		
	i. Upon submission and approval of Schematic Design at PDC as well as upon submission for verification of; <ul style="list-style-type: none"> SDP's BIM PEP to the Client BIM model at LOD 100 to the Client 	5%	5%
	ii. Upon submission for authority Planning Approval	5%	10%
	iii. Upon Planning Approval by the authority	5%	15%
c	Design Development		
	i. Upon commencement of Design Development as well as upon submission for verification of; <ul style="list-style-type: none"> Final coordinated BIM model at LOD 200 to the Client 2D drawing derived from BIM model at LOD 200 for Building Plan submission 	5%	20%
	ii. Upon Submission for authority Building Plan Approval	5%	25%
	iii. Upon Building Plan Approval by the authority	5%	30%
d	Contract Documentation Stage		
	i. Upon completion of Tender Drawings as well as upon submission for verification of; <ul style="list-style-type: none"> Final coordinated BIM model at LOD 300 to the Client Final coordinated BIM model at LOD 300 to the Contractor for reference purpose and onward BIM model usage during construction stage Clash detection coordination report together with minutes of meeting duly signed off by the Consultant BIM team to the Client 	5%	35%
	ii. Upon Completion of Tender Documents	5%	40%
	iii. Upon Award of Tender	5%	45%
e	Contract Implementation and Management		
	i. Monthly payment pro-rated over construction period as well as upon submission of; <ul style="list-style-type: none"> PQP, EMP and SHMP duly reviewed by the Consultants and briefed to the Client Clash detection coordination minutes of meeting duly signed off by the Contractor and Consultant BIM team to the Client 	35%	80%
	ii. Upon CPC and CCC	10%	90%
	iii. Upon issuance of Final Certificate and submission of as-built drawings	10%	100%

Note:

- | | |
|---|--|
| 1. PDC - Product Development Committee | 9. EMP – Environmental Management Plan |
| 2. BIM - Building Information Modelling | 10. SHMP – Safety and Health Management Plan |
| 3. PEP - Project Execution Plan | 11. CPC – Certificate of Practical Completion |
| 4. LOD - Level of Development | 12. CCC – Certificate of Completion & Compliance |
| 5. PQP - Project Quality Plan | |

The consultant shall not proceed with any stages of work without written consent from the Client.

